

TUBO EN PRFV

EXTREMOS CAMPANA Y ESPIGA

MOLDEADO POR ENROLLAMIENTO MECANICO



PRFV

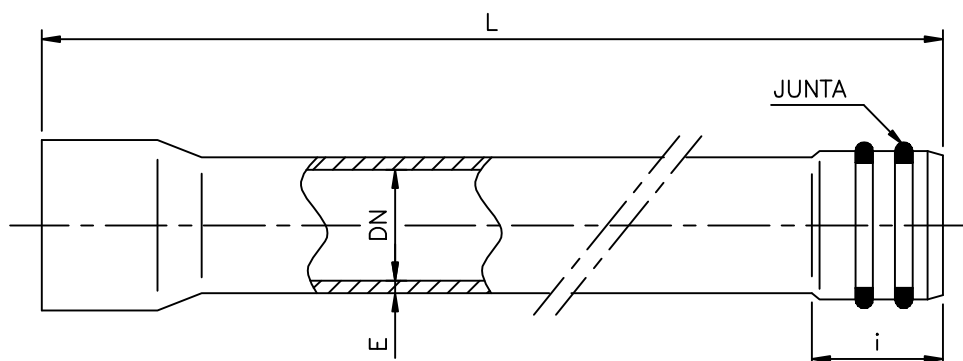

DN	L	I	JUNTA	ESPESOR "E"				
				PN2.5	PN4	PN6	PN10	PN16
125	10000	175	1	5.0	5.0	5.0	5.0	5.0
150	10000	175	1	5.0	5.0	5.0	5.0	5.1
200	12000	175	1	5.0	5.0	5.0	5.0	6
250	12000	175	1	5.0	5.0	5.0	5.2	6.8
300	12000	175	1	5.0	5.0	5.0	5.7	7.7
350	12000	200	1	5.0	5.0	5.0	6.3	8.6
400	12000	200	1	5.0	5.0	5.1	6.8	9.5
450	12000	200	1	5.0	5.0	5.4	7.4	10.3
500	12000	200	1	5.0	5.0	5.7	7.9	11.2
600	12000	200	2	5.0	5.1	6.4	9	12.9
700	12000	200	2	5.0	5.5	7	10.1	14.7
800	12000	200	2	5.0	5.9	7.7	11.1	16.4
900	12000	200	2	5.0	6.4	8.3	12.2	18.1
1000	12000	200	2	5.2	6.8	8.9	13.3	19.9
1100	12000	200	2	5.4	7.2	9.6	14.4	21.6
1200	12000	200	2	5.7	7.6	10.2	15.4	23.4

DISPONIBLES BAJO DEMANDA
LOS DIAMETROS 1300 A 3000 mm.

PARA MAS INFORMACION
ROGAMOS NOS CONSULTEN

4/04 FT105

DN: Diametro Nominal = Diametro Interior, en mm.
AC: Barrera Anticorrosion Interna de 2.5 mm
Inf. bajo reserva de cambios sin previo aviso.

PN: Presion Nominal en kg/cm²
Cotas: Expresadas en mm.

OLLEARIS S.A. Telf. +34.935796520 Fax. 34.935933616
E-mail. ollesa@ollearis.org Web. <http://www.ollearis.org>